

SpaceWire PCI Express (PCIe)

The SpaceWire PCI Express (PCIe) board is the latest addition to STAR-Dundee's SpaceWire interface device family. It provides three SpaceWire interfaces with the highly optimised host software support for the low latency transmission of SpaceWire packets directly to and from host PC. In addition a hardware RMAP target and initiator are provided for rapid RMAP prototyping solutions.

PCIe provides the essential capabilities now demanded of SpaceWire test equipment, including: Time Code Master and high speed data transfer.

The SpaceWire PCIe is suitable for all stages of SpaceWire equipment development: initial SpaceWire evaluation, instrument simulation, control system simulation, unit testing, integration support, and EGSE.

Features for the SpaceWire PCIe

- Maximum link speed of over 300Mbits/s.
- Configurable device and link speed settings.
- Fast Host communication.
- Simultaneous bi-directional communications.
- Compatible with x1, x4, x8 and x16 PCIe slots.

Device and link speed settings: The SpaceWire links can run at 300 Mbits/s with a fully configurable transmit clock speed.

High host interface bandwidth: The PCIe has a bandwidth to the host PC of 2 Gbits/s.

Simultaneous bi-directional communications: PCIe can transmit and receive simultaneously and has a direct connection to the root complex, no arbitration is required when used with other devices.

PCIe form factor compatibility: The card is a standard height X1 (half length) PCIe card and can be used in x1, x4, x8 and x16 PCIe slots without performance loss.



Key Features

Three SpaceWire interfaces: Each fully compatible with the SpaceWire standard and now able to operate at up to 300 Mbits/s. Tri-colour LEDs for each link indicate status and activity.

SpaceWire interface mode: The PCIe is a dedicated interface device which allows packets to be transmitted and received independently on each of the SpaceWire links. Traffic received on the SpaceWire links is automatically passed to software, with no

routing required. Due to its simplicity, this mode can be very useful when first using SpaceWire and simulation equipment that does not require a router.

Powerful SpaceWire routing capabilities: In addition to the Interface capabilities, the PCIe incorporates STAR-Dundee's advanced SpaceWire routing technology. In Routing Mode the PCIe is able to route packets between SpaceWire ports and between those ports and the PCI interface. Path and logical addressing are supported along with a router configuration port. This allows SpaceWire routing technology to be explored using the PCIe and makes switching of SpaceWire traffic very easy.

RMAP target and initiator port: The SpaceWire PCIe card includes a RMAP target and initiator port for rapid prototyping of RMAP systems. The port has access to 128 Mbytes of DDR3 memory and initiator control registers to setup the initiator to send RMAP commands. The port is accessible through the SpaceWire router allowing access from the PCIe interface or from the SpaceWire interfaces. The target and initiator are controllable through an extensive configuration API.

Included Software

The SpaceWire PCIe hardware is supported by STAR-Dundee's software stack, STAR-System, providing a consistent programming interface for accessing all STAR-Dundee's most recent, and future, router and interface devices, including the STAR-Dundee PCI Mk2, cPCI Mk2 and PMC Mk2 devices.

Extensive API: Developed after many years supporting users of SpaceWire interface boards, STAR-API provides a common API to all of STAR-Dundee's STAR-System products, enhancing reusability of the application software. The extensive functionality of the API makes it very easy to develop SpaceWire related application software. Example application programs further relieve the pressure on development schedules. The API provides access to all the functionality of the PCIe providing the high performance data transfer capabilities often needed for SpaceWire system simulation and testing purposes.

Software drivers: High performance drivers for the SpaceWire PCIe board are supplied for Windows and various versions of Linux operating systems. QNX and VxWorks drivers are available separately, enabling the PCIe to provide SpaceWire capability for real-time systems.

Field upgradability: The SpaceWire PCIe supports field upgradeability of the board functionality. Any upgrades or requested customisations can be downloaded from the STAR-Dundee website and installed quickly and efficiently.

Ease of use: The SpaceWire PCIe is easy to use, enabling spacecraft system and software engineers to rapidly develop the simulation, test and EGSE equipment they need.

First class support: As with all of STAR-Dundee's products, a year's support and maintenance is included with the SpaceWire PCIe. Support is provided directly from the team that developed the product allowing us to respond quickly with answers to customer questions, give assistance with application development, and resolve any problems quickly.

Overview

A block diagram of the SpaceWire PCIe board is shown below.

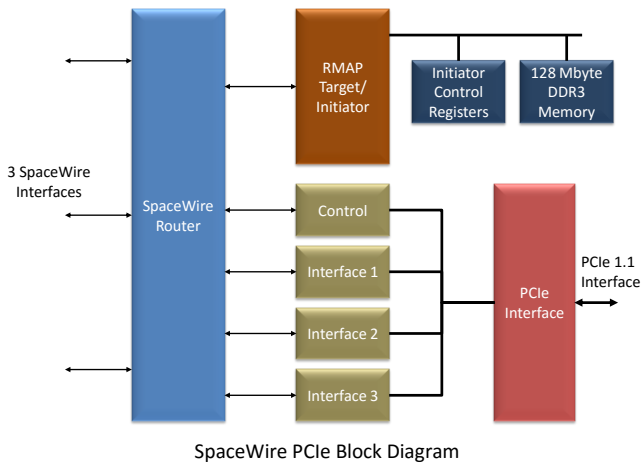

The three SpaceWire interfaces of the SpaceWire PCIe are each fully compliant to the SpaceWire standard and operate at up to 300 Mbits/s. They are connected to a SpaceWire router so that packets from one SpaceWire port can be routed to another SpaceWire port or into the host PC via the PCIe interface. There are three independent channels from the SpaceWire router to the PCIe interface, so traffic flowing over one port cannot block traffic for another port. In addition there is a separate control channel, so that the host PC is always able to access the control, configuration and status space of the PCIe regardless of the data flow.

The SpaceWire router contained in the PCIe has support for path and logical addressing, group adaptive routing, watch-dog timing and link management including power on request, and disable on silence. It includes a configuration port (port 0) for setting routing tables, configuring the SpaceWire links and monitoring their status.

The PCI Express interface is a single lane card compliant to the PCI SIG r1.0a specification. The interface benefits from dual DMA controllers for rapid transfer of data to and from the SpaceWire PCIe board.

The SpaceWire PCIe includes support for fault injection. Parity errors, credit errors, escape errors, data corruption and EEP termination of packets can all be carried out automatically or on demand.

The RMAP target and initiator port is accessible through the SpaceWire router, and therefore from the SpaceWire links and host PC. The target responds to RMAP command packets and provides access to 128 Mbytes of DDR3 memory. The initiator can be configured to send RMAP packets from packet parameters provided by the initiator control registers.

Application Programming Interface

A full API is provided to allow all functions of the SpaceWire PCIe to be controlled from user application software. A variety of programming languages are supported, including C.

The API is common across several STAR-Dundee products, and is consistent for each programming language and supported platform. This simplifies software development and allows migration of test software from one device to another and from one platform to another, enhancing software reuse and reducing the risk of schedule delays.

A key feature of the API is that it not only provides functionality to transmit and receive packets, but also functions required when testing equipment. For example, the API makes it simple to transmit packets terminated with an EEP, and to determine the end of packet marker of received packets. It simplifies the process of transmitting a stream of traffic (for example, from a file), and receiving a stream of traffic. If these streams were to include time-codes in the middle of packets, the position of these time-codes would be maintained by the API. This allows traffic streams to be recorded accurately and replayed, so multiple test runs will be consistent.

The API is provided with extensive documentation and examples, which can be used as a basis for new applications.

Specifications

API:

- C (See website for current list of supported languages).

Software:

- Application software included.
- Source code examples provided.

Supported Platforms:

- Windows drivers (Windows 7, Vista, XP, 2000), 32 and 64bit.
- Linux (3.0 and 2.6 Kernels).
- QNX and VxWorks drivers available separately.
(See website for current list of supported platforms.)

Size:

- Standard PCIe X1 (half length) board approximately 167 mm long (excluding front panel bracket).

Power:

- +3.3V DC, supplied via PCIe connector

SpaceWire Ports:

- Compliant to ECSS-E50-12A and ECSS-E-ST-50-12C.
- Number of SpaceWire Ports: 3
- Maximum Speed: 300 Mbits/s
- Data-Strobe skew tolerance: tested on all units to ± 2 ns at data rate of 200 Mbits/s
- Connectors: 9-pin micro-miniature D-type
- LVDS signalling: Using Xilinx LVDS

EMC:

- The SpaceWire PCIe board is sold as a component for inclusion in a computer unit. EMC certification is the responsibility of the user.