

A HIGH AVAILABILITY, HIGH RELIABILITY SPACEVPX SYSTEM

Steve Parkes¹, Albert Ferrer Florit², Alberto GonzalezVillafranca², Chris McClements²

¹*University of Dundee, Dundee, DD1 4HN, Scotland, UK, Phone: +44 1382 225613, Email: s.m.parkes@dundee.ac.uk*

²*STAR-Dundee Ltd., STAR House, 166 Nethergate, Dundee, DD1 4EE, Scotland, UK*

ABSTRACT

SpaceVPX is a backplane standard for demanding, high-reliability applications. Reliability is enhanced in SpaceVPX compared to VPX, by the provision for redundant payload, system controller and power supply modules. Critical signals are run in a point-to-point manner, “radially” out from the nominal and redundant system controller modules to the several payload modules. Communication functions are isolated from one another using several planes: data plane, control plane, management plane and utility plane.

SpaceFibre is a high-availability, high-reliability, high-performance serial communication standard, which provides multiple virtual channels over each communication link. These virtual channels are isolated from one another and each has configurable quality of service (QoS). SpaceFibre provides multi-lane communication with graceful degradation in performance if a lane fails. Hot and cold redundancy can be provided within a multi-lane link with very fast (2 μ s) detection and recovery from failures.

The full paper introduces SpaceVPX and SpaceVPX-Lite and then outlines the key features of SpaceFibre. It then explains how a single communications plane can replace the data, control and management plane in SpaceVPX to advantage: reducing power consumption, reducing complexity, increasing availability and enhancing reliability.

1. SPACEFIBRE VIRTUAL CHANNELS

A SpaceFibre interface includes a number of virtual channels [9]. Each provides a FIFO type interface similar to that of a SpaceWire link. When data from a SpaceFibre packet is placed in a SpaceFibre virtual channel it is transferred over the SpaceFibre link and placed in the same numbered virtual channel at the other end of the link. Data from the several virtual channels are interleaved over the physical SpaceFibre connection. A virtual channel can be assigned a quality of service which determines the precedence with which that virtual channel will compete with other virtual channels for sending data over the SpaceFibre link. Priority, bandwidth reservation, and scheduled qualities of service can be supported, all operating together using a simple precedence mechanism.

To provide quality of service, it is necessary to be able to interleave different data flows over a data link or network. If a large packet is being sent with low priority and a higher priority one requests to be sent, it must be possible to suspend sending the low priority one and start sending the higher priority packet. To support the interleaving, packets are chopped up and sent in short frames of up to 256 SpaceFibre N-chars each. An N-Char is a data byte, End of Packet marker (EOP) or Error End of Packet marker (EEP). When the high priority packet requests to be sent, the current frame of the low priority packet is allowed to complete transmission, and then the frames of the high priority packet are sent. When all the frames of the high priority packet have been sent, the remaining frames of the low priority packet can be sent. Each frame has to be identified as belonging to a particular data flow so that the stream of packets can be reconstructed at the other end of the link.

Each independent data stream allowed to flow over a data link is referred to as a virtual channel (VC). Virtual channels are unidirectional and have a QoS attribute. The QoS attributes are priority, allocated bandwidth and schedule. Together these attributes determine the precedence of a virtual channel. If one virtual channel exceeds its allocated bandwidth, the precedence of that virtual channel is automatically reduced so that its use of link bandwidth is constrained and it cannot adversely affect the traffic in other virtual channels.

2. SPACEFIBRE AS THE CONTROL PLANE

SpaceVPX and SpaceVPXLite use SpaceWire as a control plane. SpaceWire is widely used in space applications, supports moderate data rates and has a small footprint. There are two disadvantages of using SpaceWire: lack of AC coupling which requires special cold sparing interfaces and the fact that a SpaceWire interface requires eight signal wires.

SpaceFibre has been designed to be backwards compatible with SpaceWire at the network level, so it is possible to replace a SpaceWire based control plane with a SpaceFibre control plane, without having to change the application software. Two lanes of SpaceFibre can be run over the same number of backplane signals as a SpaceWire link. This results in 6.25 Gbps data-signalling rate and graceful degradation of the control plane connection. If one SpaceFibre lane fails, the other one keeps going, transferring the critical control information. The SpaceFibre virtual channels allow different classes of traffic to be sent over independent virtual channels, allowing control information to be sent over one virtual channel, possible management information over another, and application data over other virtual channels. Essential separation of control information is maintained via the virtual channels. Control information can be given high priority, as well as a reserved bandwidth allocation to ensure that this critical information is delivered in the event of a lane failure in a multi-lane link.

3. INTEGRATING MANAGEMENT PLANE FUNCTIONS INTO THE CONTROL PLANE

The control plane goes to all of the payload modules from each of the system controllers using “radial” point-to-point links. This means that there is no need for management plane signals to carry the system management information to the payload modules. Normally passed over an I2C bus, the system management information can be sent over SpaceWire or SpaceFibre using the Remote Memory Access Protocol to access the management control and status register in the payload boards. This capability is being added to SpaceVPX. When SpaceFibre is used as the control plane, a separate virtual channel can be allocated to the system management function. This means that the two I2C buses that would normally run one from each system controller to all of the payload modules are replaced by radial point-to-point connections, which is much better from the reliability perspective. As can be seen in Figure 1, this reduces the complexity of the backplane.

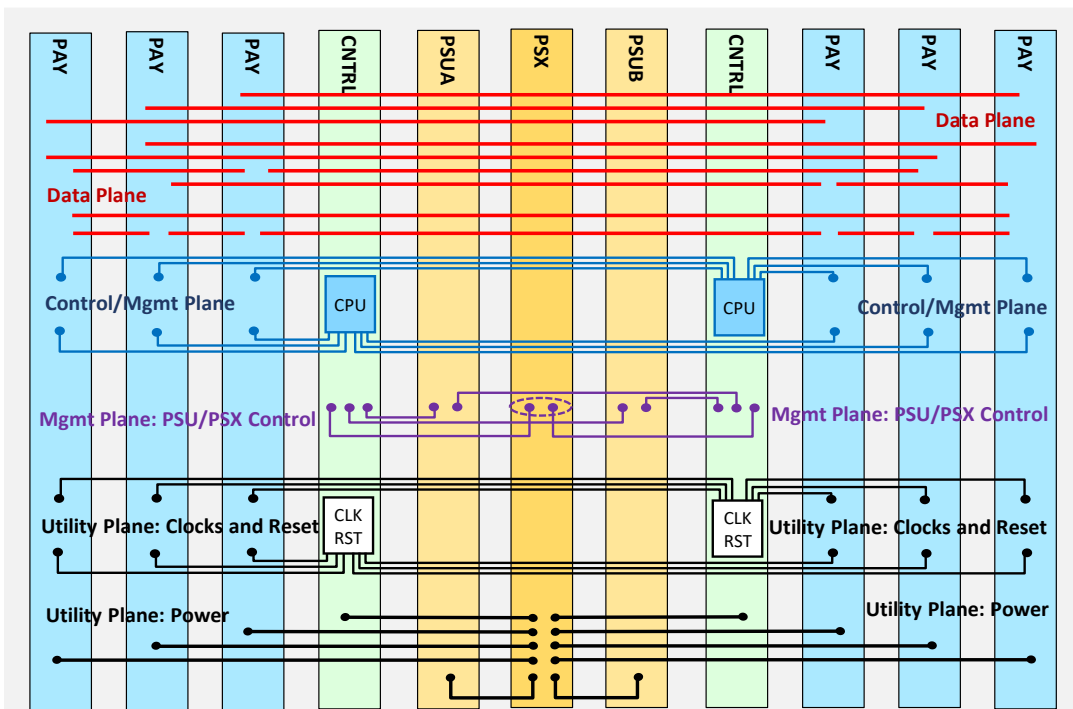

Figure 1: SpaceVPX-Lite Backplane with Combined Control/Management Plane to the Payload Modules

4. SPACEFIBRE DATA PLANE

SpaceFibre can be used as the data plane in a SpaceVPX system because it is fully compatible with the 100 ohm differential impedance backplane connections provided for the data plane. A SpaceFibre interface with up to four lanes can be used to provide data rates of up to 12.5 Gbps (10 Gbps data throughput) with current radiation tolerant implementations. Data rates of double this 25 Gbps are expected in the next couple of years in radiation tolerant technology.

5. INTEGRATED DATA AND CONTROL PLANE

With SpaceFibre as both a control and data plane the possibility of integrating both planes as two virtual planes in one physical plane becomes possible. This takes advantage of the virtual channels in SpaceFibre with one virtual channel for management information, one for control information and one or more for payload data. This is illustrated in Figure 2.

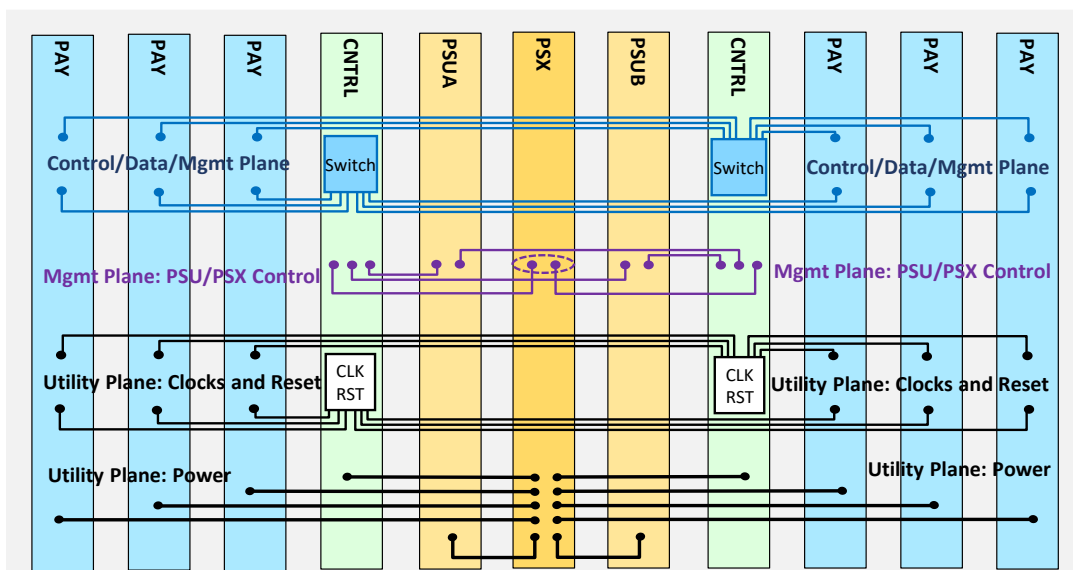

Figure 2: SpaceVPX Backplane with Combined Control, Data and Payload Management Plane

A single physical plane that carries several virtual planes has a number of advantages:

- Improved reliability: With three physical lanes, any one of those lanes failing results in loss of the system. With one physical lane the reliability is, therefore, improved.
- Easier to add redundancy: With fewer physical wires it is easier to add redundancy. Redundancy can take the form of redundant links or redundant lanes.
- Improved performance: Multiple lane links can replace the SpaceWire control plane and SpaceFibre data plane. This multi-lane link provides improved performance.
- Graceful degradation and hot/cold redundancy: A failure of a lane in a multi-lane link results in reduce performance. The link degrades gracefully, with lower priority, less important, traffic not being able to travel over the link. A redundant lane can provide either hot redundancy, where a hot redundant lane can take over from a failed lane in a few μs , or cold redundancy, where a spare lane is enabled after a fault is detected. For cold redundancy with two operational lanes, a lane failure will be detected in a few μs and link operation will continue with half bandwidth, the cold redundant lane can then be enabled and it will then take of the order of 100 μs for the lane to initialize and restore full operation. In the meantime, any critical control and management information is still able to travel over the link.

It is possible to provide a SpaceFibre routing switch on the system controller, which is able to switch data between the system controller and the payload modules. This allows a payload module to talk to any other

payload module. Each payload module can be allocated its own virtual channel which, with the routing switch, forms a virtual network so that the each payload module can be allocated a bandwidth for sending and receiving data other payload modules.

6. A SPACEVPX-LITE DEMONSTRATION BOARD

A demonstration board for SpaceFibre in SpaceVPXLite has being developed by STAR-Dundee, which is shown in Figure 3. The principal component on the SpaceVPX-RTG4 board is a Microsemi RTG4 FPGA [5][11]. The Microsemi RTG4 is a new generation radiation tolerant FPGA with extensive logic, memory, DSP blocks, and IO capabilities and built in triple mode redundancy. The RTG4 provides 16 SpaceWire clock-data recovery circuits and 24 multi-Gbps SerDes lanes to support high-speed serial protocols like SpaceFibre.

Attached to the RTG4 are two banks of 32-bit wide DDR memory. A pair of SpaceWire and a pair of SpaceFibre connectors are provided on the front panel of the SpaceVPX-RTG4 board. To provide additional input/output functions an FMC connector is provided on the board. The SpaceVPX-RTG4 can be configured as either a system controller or a payload module, with SpaceWire or SpaceFibre control plane connections.



Figure 3 SpaceVPX-RTG4 Board with Dual ADC FMC card fitted

7. CONCLUSIONS

SpaceVPX and SpaceVPX-Lite have been introduced and the key features of SpaceFibre outlined. The way in which SpaceFibre can be used to replace the data, control and management plane in SpaceVPX with a single physical plane with separate virtual channels providing isolated virtual planes has been described. This provides several advantages reduced power consumption, reduced complexity, increased availability and enhanced reliability. A SpaceFibre-VPX demonstration board has been developed which can be configured as either a system controller or as a payload module.

8. ACKNOWLEDGMENTS

The research leading to these results has received funding from the European Space Agency under ESA contract numbers 4000102641 (SpaceFibre) and 17938/03/NL/LvH (SpaceFibre), from the European Union Seventh Framework Programme (FP7/2007-2013) under grant agreement numbers 263148 (SpaceWire-RT) and 284389 (VHISSI), and from the UK Space Agency and CEOI-ST under University of Leicester contract numbers: RP10G0348A02 (SUNRISE), RP10G0348B206 (SpaceFibre-VPX) and RP10G0348A207 (SpaceDSP).