

# SUNRISE: A SpaceFibre Router

Steve Parkes<sup>(1)</sup>, Chris McClements<sup>(1)</sup>, David McLaren<sup>(1)</sup>,

Albert Ferrer Florit<sup>(2)</sup> and Alberto Gonzalez Villafranca<sup>(2)</sup>

<sup>(1)</sup>University of Dundee, Space Technology Centre, Dundee, DD1 4HN, Scotland, UK.

Email: [sparkes@computing.dundee.ac.uk](mailto:sparkes@computing.dundee.ac.uk); [c.mcclements@computing.dundee.ac.uk](mailto:c.mcclements@computing.dundee.ac.uk)

<sup>(2)</sup>STAR-Dundee Ltd, STAR House, 166 Nethergate, Dundee, DD1 4EE, Scotland, UK.

Email: [albert.ferrer@star-dundee.com](mailto:albert.ferrer@star-dundee.com); [albert.gonzalez@star-dundee.com](mailto:albert.gonzalez@star-dundee.com)

## ABSTRACT

SpaceFibre is a new generation of SpaceWire technology which is able to support the very high data-rates required by sensors like SAR and multi-spectral imagers. Data rates of between 1 and 16 Gbits/s are required to support several sensors currently being planned. In addition a mass-memory unit requires high performance networking to interconnect many memory modules. SpaceFibre runs over both electrical and fibre-optic media and provides and adds quality of service and fault detection, isolation and recovery technology to the network. SpaceFibre is compatible with the widely used SpaceWire protocol at the network level allowing existing SpaceWire devices to be readily incorporated into a SpaceFibre network. SpaceFibre provides 2 to 5 Gbits/s links (2.5 to 6.25 Gbits/s data signalling rate) which can be operated in parallel (multi-laning) to give higher data rates. STAR-Dundee with University of Dundee has designed and tested several SpaceFibre interface devices.

The SUNRISE project is a UK Space Agency, Centre for Earth Observation and Space Technology (CEOI-ST) project in which STAR-Dundee and University of Dundee will design and prototype critical SpaceFibre router technology necessary for future on-board data-handling systems. This will lay a vital foundation for future very high data-rate sensor and telecommunications systems.

This paper give a brief introduction to SpaceFibre, explains the operation of a SpaceFibre network, and then describes the SUNRISE SpaceFibre Router. The initial results of the SUNRISE project are described.

## 1 INTRODUCTION

SpaceFibre [1] [2] [3] [4] is a multi-gigabit/s serial network technology being designed specifically for

spaceflight applications. SpaceFibre aims to support high data-rate payloads, for example synthetic aperture radar and hyper-spectral optical instruments. It provides robust, long distance communications for launcher applications and supports avionics applications with deterministic delivery capability.

Developed by the University of Dundee for the European Space Agency (ESA) SpaceFibre is able to operate over fibre-optic and electrical cable and supports data rates of 2 Gbit/s in the near future and up to 5 Gbit/s long-term. Multi-laning improves the data-rate further to well over 20 Gbits/s.

SpaceFibre provides a quality of service mechanism able to support priority, bandwidth reservation and scheduling. It incorporates fault detection, isolation and recovery (FDIR) capability in the interface hardware. It is designed to be implemented efficiently, requiring only three times the number of logic gates of a SpaceWire [5] interface while providing many capabilities missing from SpaceWire. SpaceFibre is backwards compatible with SpaceWire at the network level, using the same packet format, which allows simple interconnection of existing SpaceWire equipment to a SpaceFibre link or network.

## 2 SPACEFIBRE NETWORKS AND ROUTING SWITCHES

A SpaceFibre network uses similar packet formats, packet addressing and routing concepts to SpaceWire. The main difference is that SpaceFibre includes virtual channels.

An example SpaceFibre router is illustrated in Figure 2-1.

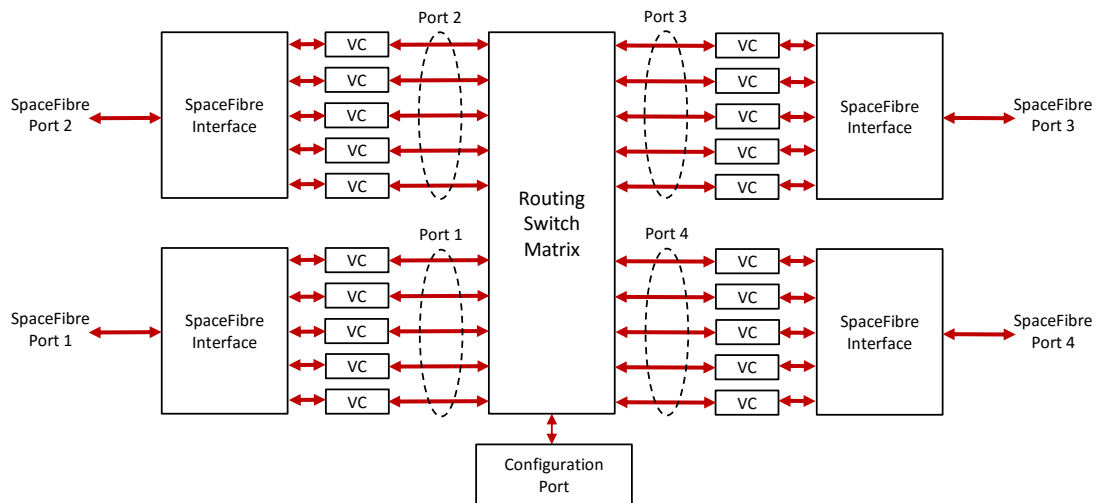

**Figure 2-1 SpaceFibre Router**

The SpaceFibre router comprises a number of SpaceFibre interfaces and a routing switch matrix. Each SpaceFibre interface has several virtual channels (VCs). The VC number for each virtual channel can be configured, except for VC0 which is a virtual channel used for configuration, control and monitoring of the SpaceFibre network. When a packet arrives on a SpaceFibre interface it is placed in the appropriate virtual channel, i.e. the one with the same VC number as it was transmitted on. The leading data character of the packet determines which port of the routing switch the packet is to be forwarded through using either path or logical addressing. The port that it is to be switched to must have a VC configured with the same number as the VC that the packet arrived on. The packet is then passed through the routing switch matrix and placed frame by frame in the VC of the output port. The packet

is then transferred across the SpaceFibre link, competing with other VCs in that port for access to the link medium according to their precedence [3].

If a packet arrives and the output port that the packet is to be switched to, does not have a VC with the same number as that on which it arrived, the packet is split and an error recorded.

Virtual channels can be used to construct virtual networks, where a single VC number is used for connecting to all or several of the nodes attached to the network. This is illustrated in Figure 2-2 where VC6 (blue) is used to connect all the nodes on the network. Using VC6 the Control Processor can send commands to Instrument 1 or 2 or the Mass Memory unit, setting their operating mode or reading housekeeping information, etc. This virtual network acts like a SpaceWire network.

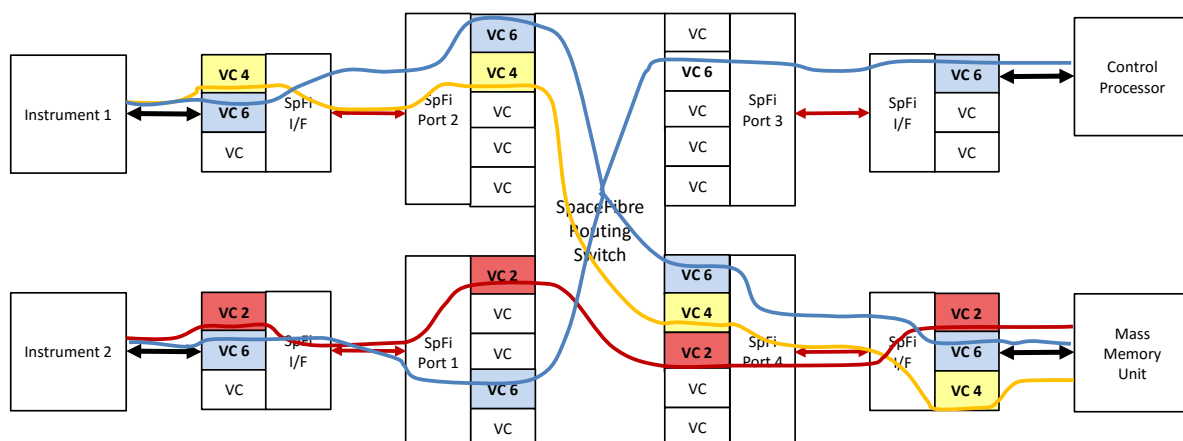

**Figure 2-2 Simple SpaceFibre Network**

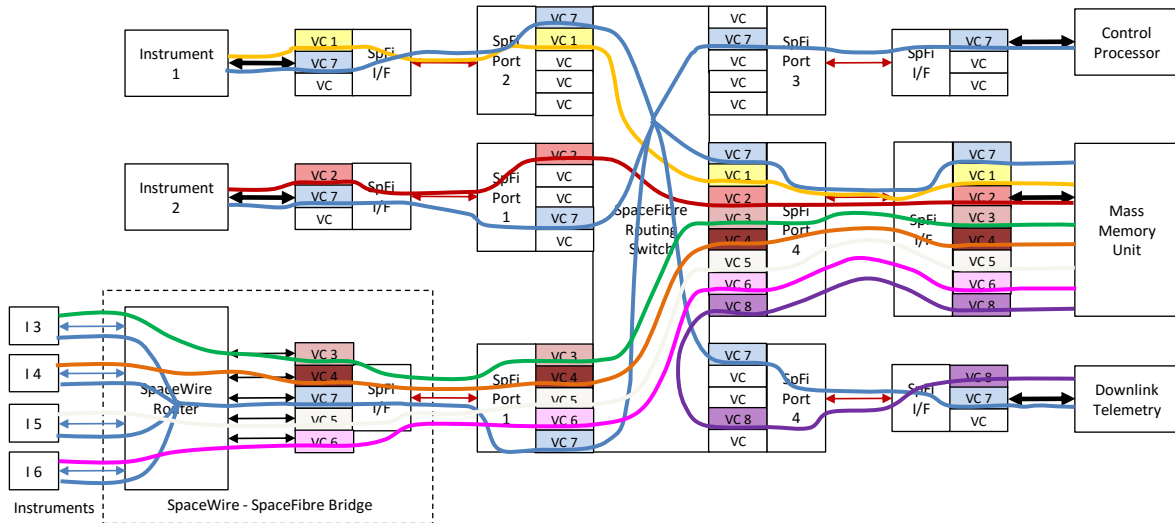
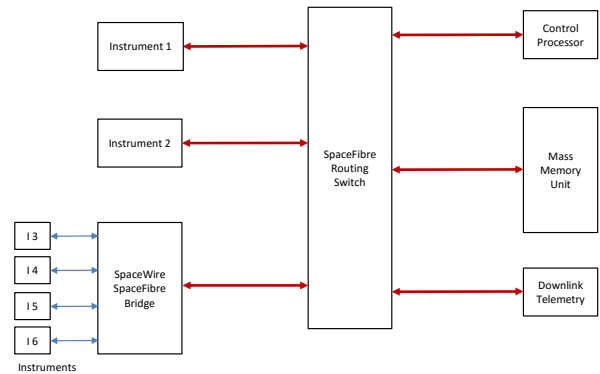

**Figure 2-3 Realistic SpaceFibre Network**

Virtual channels can also be used to construct virtual point-to-point links from one node to another. VC2 and VC4, in Figure 2-2, are providing virtual point-to-point links. VC2 provides a virtual point-to-point link between Instrument 2 and the Mass Memory Unit and VC4 between Instrument 1 and the Mass Memory. These virtual channels can be each allocated the bandwidth they need to send their data to the Mass Memory Unit. Once this bandwidth is allocated other virtual channels or virtual networks will not interfere with their operation.

Figure 2-3 shows a more realistic on-board network using SpaceFibre which includes a SpaceWire to SpaceFibre Bridge. Two high data-rate instruments (Instruments 1 and 2) have SpaceFibre connections. Four less demanding instruments have SpaceWire connections to the SpaceWire to SpaceFibre Bridge. Each instrument has a virtual point-to-point connection to the Mass Memory Unit and there is a virtual point-to-point connection between the Mass Memory and the Downlink Telemetry Unit. The Control Processor has a virtual network for configuring and controlling all devices on the network.

Figure 2-3 is solving a complex communication task with many separate, isolated virtual channels providing point-to-point links, and a virtual network being used to control the entire system. Figure 2-4 shows this same network with the virtual channels removed, revealing the simplicity of implementation of a complex communication task when using SpaceFibre.



**Figure 2-4 Simple System Architecture with SpaceFibre**

### 3 SUNRISE

A SpaceFibre router has been designed and implemented in the SUNRISE project. The architecture of this router is shown in Figure 3-1.

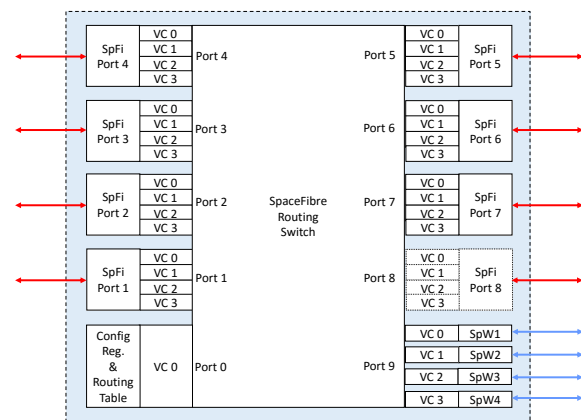

**Figure 3-1 SUNRISE SpaceFibre Router Architecture**

The SUNRISE router has eight SpaceFibre ports, numbered 1 to 8, each with four virtual channels. There is a configuration port (port 0) which is used for device configuration and which can be accessed using virtual channel 0 of any of the other ports. Another port (port 9) provides an interface to four SpaceWire ports using four virtual channels, one for each SpaceWire port. SpaceWire and SpaceFibre packets are switched by the routing switch in the same way, using the leading data character of a packet to determine the output port that the packet is to be switched to. Both path and logical addressing can be used.

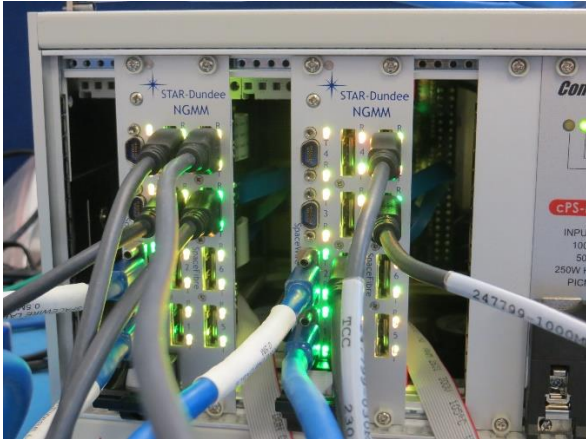

**Figure 3-2 SUNRISE SpaceFibre Routers Under Test**

The SUNRISE router has been implemented initially in a Xilinx Spartan 6 FPGA. Two of the SUNRISE routers are shown under test in Figure 3-2. The SUNRISE prototype are implemented on 3U cPCI/PXI boards. Power is taken from the backplane and the

eight SpaceFibre and four SpaceWire ports are available on the 40mm wide front panel.

#### 4 DEMONSTRATION SYSTEM

The SUNRISE SpaceFibre routing switches were incorporated in an extensive demonstration system to show various aspects of SpaceFibre. The demonstration system architecture is illustrated in Figure 4-1 which is based on the on-board data-handling architecture described in Figure 2-3 and Figure 2-4. There are two high data rate instruments (Instrument 1 and 2), some SpaceWire based instruments connected via a SpaceWire to SpaceFibre bridge, a pair of SpaceFibre routers (to allow various router capabilities to be explored), a control processor, a mass-memory and a downlink telemetry unit.

The way that these various units have been implemented is illustrated in Figure 4-2.

Instruments 1 and 2 are implemented using a STAR Fire unit which has two SpaceWire and two SpaceFibre interfaces. The SpaceFibre interfaces each have eight virtual channels, two connected to an internal SpaceWire router and the other six connected to internal high-speed packet generators/checker. The STAR Fire unit can operate as a high-speed data source (packet generator), a high-speed data sink (packet checker), a SpaceWire to SpaceFibre bridge (for two SpaceWire ports and also a USB port), and as a SpaceFibre link analyser.

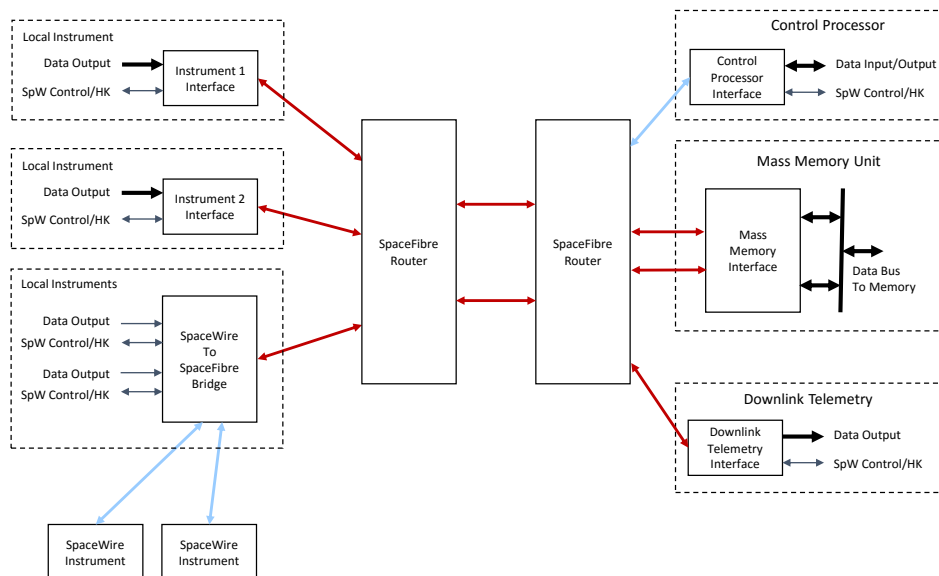

**Figure 4-1 SUNRISE SpaceFibre Router Demonstration System Architecture**

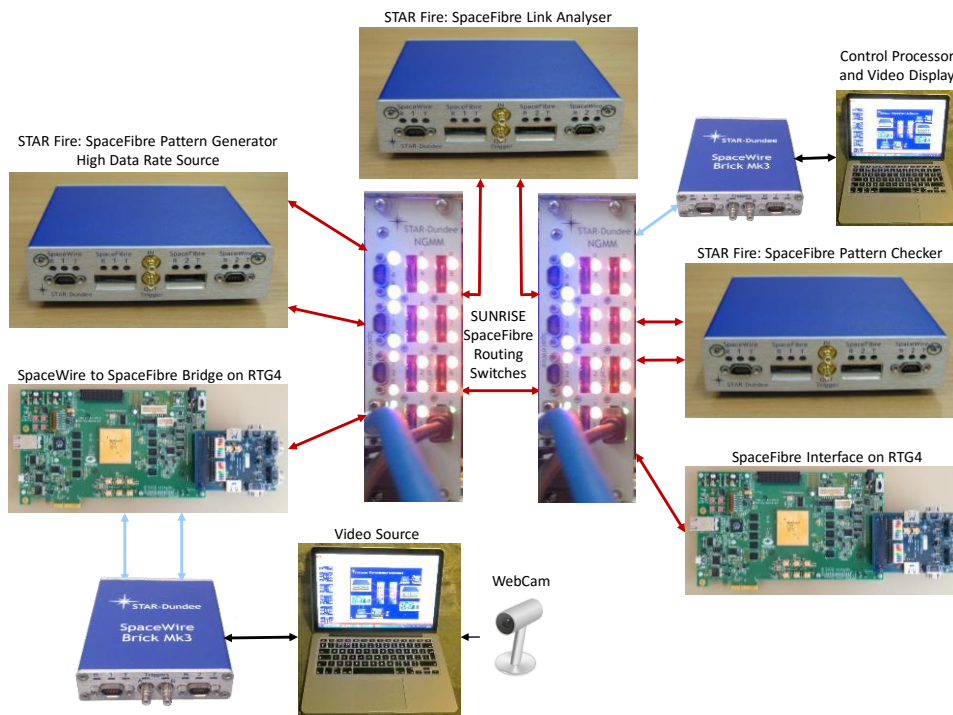

**Figure 4-2 SUNRISE SpaceFibre Router Demonstration System Components**

A Microsemi RTG4 FPGA development board is used to implement a SpaceWire to SpaceFibre Bridge which is used to connect video (from a webcam) and other low data rate sources generated on a PC. This PC is connected via USB 3.0 to a SpaceWire Brick Mk3 which provides two SpaceWire interfaces for the PC. The two SpaceWire links are connected to the Microsemi RTG4 SpaceWire to SpaceFibre Bridge, with the packets from each SpaceWire link travelling over a separate SpaceFibre virtual channel.

The SpaceFibre links from the STAR Fire unit (Instruments 1 and 2) and the SpaceWire to SpaceFibre Bridge (RTG4 board) are connected to one of the SUNRISE SpaceFibre routers. The two routers are interconnected by a couple of SpaceFibre links, one of which passes through another STAR Fire unit acting as a SpaceFibre link analyser, so that the traffic over that link can be captured and displayed.

The second SUNRISE SpaceFibre router is connected to another STAR Fire unit which is acting as a mass memory unit, receiving SpaceFibre packets. The packets received are checked by packet checkers inside the STAR Fire unit. This STAR Fire unit also sends SpaceFibre packets to a second RTG4 FPGA board, which corresponds to a downlink telemetry unit, receiving packets.

The video data from the webcam is routed to one of the SpaceWire ports of the second SUNRISE SpaceFibre

router. It then passes through a SpaceWire Brick Mk3 and ends up in a second PC where the video data is displayed. This PC also acts as overall control processor, setting up and monitoring the operation of the SpaceFibre network.

The demonstration system has shown the operation of SpaceFibre in a network architecture representative of a typical spaceflight on-board data-handling architecture. The SpaceFibre links were all operating at 2.5 Gbits/s. SpaceFibre was shown operating and interoperating on Xilinx Spartan 6 FPGAs and Microsemi radiation tolerant RTG4 FPGAs.

## 5 RADIATION TOLERANT SPACEFIBRE ROUTING SWITCH

A radiation tolerant version of the SUNRISE SpaceFibre routing switch is currently being implemented in the RTG4 FPGA [4]. The full paper will provide further details on this design.

## 6 CONCLUSIONS

SpaceFibre is now in the process of being adopted as a formal ECSS standard. Providing multi-gigabit/s communications it incorporates a comprehensive quality of service capability providing integrated bandwidth reservation, priority and scheduling.

Efficient, effective and rapid fault detection, isolation and recovery mechanisms are included in the SpaceFibre interface, enabling fast detection and recovery from link level errors. SpaceFibre has been implemented and tested in a range of FPGAs including the Microsemi RTAX with external SerDes device and the RTG4 with internal SerDes.

The SUNRISE activity has designed, implemented and tested a versatile, high-performance SpaceFibre routing switch. It has demonstrated the operation of this routing switch in a network architecture representative of a spaceflight on-board, data-handling architecture. A radiation tolerant version of the SUNRISE router is currently under development and the results of this work will be reported in the full paper.

## 7 ACKNOWLEDGMENTS

The research leading to these results has received funding from the European Space Agency under ESA contract numbers 4000102641 and 17938/03/NL/LvH, from the European Union Seventh Framework Programme (FP7/2007-2013) under grant agreement numbers 263148 and 284389 and from the UK Space Agency via the Centre for Earth Observation Instrumentation and Space Technology (CEOI-ST). We would also like to thank Martin Suess the ESA project manager for the SpaceFibre related activities for his help, advice and guidance.

## 8 REFERENCES

- [1] S. Parkes, A. Ferrer and A. Gonzalez, "SpaceFibre Standard", Draft H1 September 2015, available from <http://space-env.esa.int/indico/confLogin.py?confId=32>
- [2] S. Parkes, C. McClements and M. Suess, "SpaceFibre", International SpaceWire Conference, St Petersburg, Russia, 2010, ISBN 978-0-9557196-2-2, pp 41-45.
- [3] S. Parkes et al, "SpaceFibre: Multi-Gigabit/s Interconnect for Spacecraft On-board Data Handling", IEEE Aerospace Conference, Big Sky, Montana, 2015.
- [4] S. Parkes et al, "SpaceWire and SpaceFibre on the Microsemi RTG4 FPGA", IEEE Aerospace Conference, Big Sky, Montana, 2016.
- [5] ECSS Standard ECSS-E-ST-50-12C, "SpaceWire, Links, Nodes, Routers and Networks", Issue 1, European Cooperation for Space Data Standardization, July 2008.