

STAR-Dundee

SpaceWire and SpaceFibre Expertise

STAR-Ultra PCIe

The STAR-Ultra PCIe is a **SpaceFibre Multi-Lane interface and link analyser**, designed to aid test and development of SpaceFibre equipment. It can transmit and receive SpaceFibre traffic from a host PC at data rates in excess of 10 Gbit/s, and it can record and display SpaceFibre traffic transmitted and received on one SpaceFibre port.

The STAR-Ultra PCIe is controlled by a host PC, connected by an eight-lane Gen 3 PCIe interface, and has two quad-lane SpaceFibre interfaces. Each SpaceFibre lane can operate at a data signalling rate of up to 6.25 Gbit/s, resulting in a maximum link speed of 25 Gbit/s.



STAR-Ultra PCIe

SpaceFibre Multi-Lane Interface

The STAR-Ultra PCIe can transmit and receive SpaceFibre packets and broadcasts at high-speed from a host PC (in excess of 10 Gbit/s on a typical computer). Connected by a PCIe interface, each SpaceFibre virtual channel (VC) has a dedicated software channel, allowing each to operate independently. Packets can quickly be transmitted and received using the provided command line and graphical user interface (GUI) applications, or custom software can be written to meet specific requirements using application programming interfaces (APIs). The SpaceFibre Multi-Lane interface functionality of the STAR-Ultra PCIe can be used for a range of SpaceFibre test and development purposes: initial SpaceFibre evaluation, instrument simulation and stimulation, unit testing, and integration support.

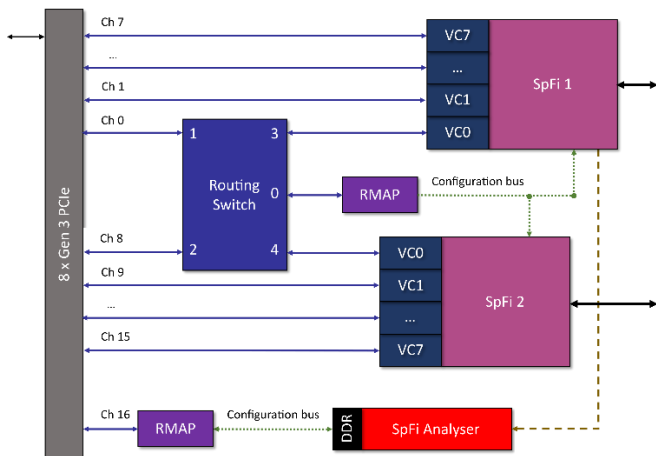

STAR-Ultra PCIe Functional Block Diagram

SpaceFibre Link Analyser

The STAR-Ultra PCIe can unobtrusively capture SpaceFibre traffic transmitted and received on SpaceFibre port one. Over 11 million traffic items (more intended following software updates) can be

captured to hardware memory when a pre-defined capture trigger event is detected. Once capture has completed, the SpaceFibre traffic is uploaded to a host PC where it is presented in different levels of detail in multiple displays: network, packet, frame and word views. These views can be used to validate and debug SpaceFibre equipment.

Key Features

Two SpaceFibre Multi-Lane interfaces: Both fully compatible with the SpaceFibre standard. Single, dual, triple and quad lane configurations are supported, with lane data signalling rates configurable up to 6.25 Gbit/s, resulting in a **maximum aggregate link speed of 25 Gbit/s**. The Multi-Lane interfaces provide:

- **Graceful degradation:** Should link bandwidth reduce for any reason, higher priority virtual channels are less affected, preserving critical information.
- **Hot and cold lane redundancy:** Rapidly switch to a redundant lane in the event of a lane failure, without user intervention, in less than 3 μ s.
- **Asymmetric links:** Lanes can be configured as unidirectional to save power and mass in asymmetric data flows.

Eight virtual channels per SpaceFibre interface: Each with configurable quality of service (QoS): priority, bandwidth allocation and a schedule.

High-speed interface to host PC: An eight-lane Gen 3 PCIe interface connects the STAR-Ultra PCIe to a host PC, allowing SpaceFibre packets to be transmitted and received from software at high-speed. Each VC has a dedicated STAR-System software channel: VCs 1 to 7 operate at high-speed, whilst VC 0 is typically reserved for configuration.

QSFP connectors: Support for electrical or fibre optic cables (with fibre optic transceiver).

RMAP support: Build RMAP packets to be transmitted, and interpret RMAP packets received, using the RMAP Packet Library API. Additionally, transmit RMAP commands and receive replies using the RMAP Initiator GUI application.

Configurable capture trigger: Set the STAR-Ultra PCIe to capture SpaceFibre traffic when specific symbols, words or errors are detected.

Large capture memory: Over 11 million traffic items can be unobtrusively captured to hardware memory when the capture trigger is detected. For efficient memory usage, the proportion of pre- and post-trigger memory reserved around the capture trigger is configurable. If appropriate, memory can be used more effectively still, using filtering to disable idle frame capture.

Enable de-scrambling: Scrambled data can be captured and viewed either scrambled or de-scrambled to simplify data analysis.

Field upgradability: The STAR-Ultra PCIe supports field upgradability of the unit functionality. Any upgrades or requested customisations can be downloaded from the STAR-Dundee website and installed quickly and efficiently.

User friendly software: Multiple graphical applications for STAR-Ultra PCIe control and display purposes are included. Help menus/buttons provide descriptions of application components and SpaceFibre properties to aid software use.

First class support: As with all of STAR-Dundee’s products, a year’s support and maintenance is included with the STAR-Ultra PCIe. This support is provided directly from the team that developed each product so that we can respond quickly with detailed answers to questions, give assistance with application development, and resolve any problems quickly.

STAR-Ultra PCIe Software

Three GUI software applications are provided to support the STAR-Ultra PCIe's SpaceFibre capabilities.

STAR-Ultra PCIe Controller: View and modify SpaceFibre interface properties including link status and settings, virtual channel QoS, lane settings and status, and network management settings. The settings of other STAR-Ultra PCIe devices on the same SpaceFibre network can be accessed remotely.

STAR-Ultra PCIe Statistics: Displays live virtual channel statistics including transmit and receive data rates. To help visualise the effects of virtual channel QoS and data rate changes, transmit and receive percentage link utilisation are graphed over time.

STAR-Ultra PCIe Link Analyser: Enables the STAR-Ultra PCIe to be used as a SpaceFibre link analyser, capable of capturing and displaying SpaceFibre link traffic. Capture mode, memory, capture trigger, filter and scrambling settings are configurable prior to traffic capture. Once captured, SpaceFibre traffic is displayed in multiple time synchronised views:

- **Network View:** Network level display that provides a high-level overview of all captured SpaceFibre traffic in varying quantities and detail depending on the zoom level.
- **Packet View:** Displays packet timing, size and contents for each virtual channel. **RMAP protocol analysis** displays the fields of packets conforming to the RMAP standard.
- **Frame View:** Displays interleaving data and broadcast frames.
- **Word View:** Shows captured SpaceFibre words and corresponding symbols.

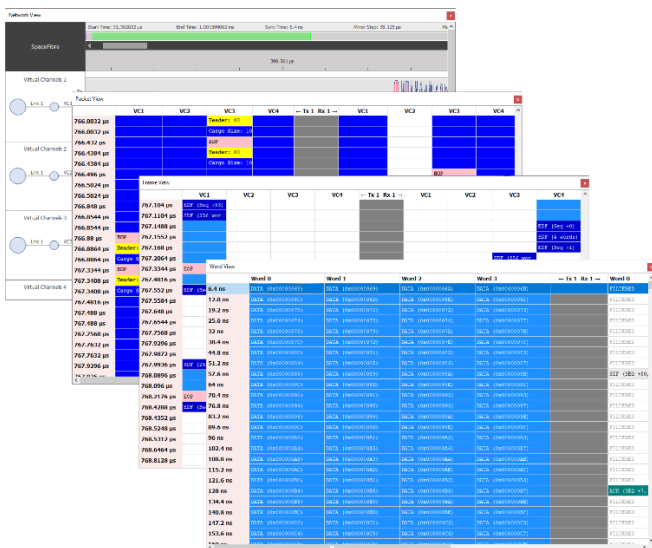

STAR-Ultra PCIe Link Analyser Views

The packet and word views have **built-in search capabilities** to help navigate and validate captured traffic. If required, the data can be exported to a CSV file for custom software to interpret.

STAR-Ultra PCIe API

The STAR-Ultra PCIe is also provided with a C API to control the SpaceFibre Multi-Lane interface and link analyser functionality from custom software. This can be used to integrate the STAR-Ultra PCIe functionality into existing software systems and to write automated tests.

STAR-System

The STAR-Ultra PCIe is supported by our software stack, STAR-System, providing a consistent programming interface for accessing all STAR-Dundee’s most recent, and future, router and interface devices. This includes:

- **Software drivers:** High performance drivers for the STAR-Ultra PCIe are supplied for Windows and Linux. STAR-System is regularly updated to support the latest versions of both operating systems.
- **C and C++ APIs:** Transmit and receive SpaceFibre packets and broadcasts from custom software. The API is common across several STAR-Dundee products promoting software reuse across different devices. Example code and comprehensive documentation are provided.
- **Software applications:** Example command line applications are provided with source code to demonstrate common tasks, and to test a device’s throughput and latency. GUI applications are also provided to support the transmission and reception of SpaceFibre packets.

Specifications

Part Number	163
Size	<ul style="list-style-type: none"> • Half-length PCIe board with x16 connector. Both low-profile and full-height brackets provided. • 174 x 68.9 x 32.5 mm
Power	Supplied via PCIe connector
Software	<ul style="list-style-type: none"> • Application software included • C APIs with examples
Platforms	<ul style="list-style-type: none"> • Windows (10, 8 and 7) • Linux (5.x, 4.x and 3.x kernels)
SpaceFibre Ports	<ul style="list-style-type: none"> • Compliant to ECSS-E-ST-50-11C • Number of SpaceFibre Ports: 2 • Number of Virtual Channels: 8 • Single, dual, triple or quad lane configuration • Configurable lane data signalling rate: 1.25, 2.5, 3.125, 5.0 or 6.25 Gbit/s • Hot and cold lane redundancy support • Asymmetric link support via configurable unidirectional lanes • Connectors: QSFP
PCIe Interface	<ul style="list-style-type: none"> • Host Interface: PCI Express Gen 3 x8 • Board Format: x16 connector
EMC	The STAR-Ultra PCIe board is sold as a component for inclusion in a computer unit. EMC certification is the responsibility of the user.

All information provided is believed to be accurate at time of publication. Please contact STAR-Dundee for the most recent details. © 2021 STAR-Dundee Ltd.



STAR-Dundee Ltd.
 STAR House
 166 Nethergate
 Dundee
 DD1 4EE
 Scotland, UK

Tel: +44 1382 201755
 Fax: +44 1382 388838
 E-mail: enquiries@star-dundee.com
 Web: www.star-dundee.com
 Twitter: @STAR_Dundee
 LinkedIn: STAR-Dundee